

Spoolmatic® and XR-Pistol™

Pistol-Grip Guns

MIG Guns for Aluminum Welding 

Quick Specs

Heavy Industrial Applications

Emergency vehicles	Shipbuilding
Recreational vehicles	Tool boxes
Trucks and trailers	Railcars
Boat/yacht building	Fabrication
Sign manufacturers	

Processes

MIG (GMAW) with aluminum wire and other soft alloys
Pulsed MIG (GMAW-P) with pulsing power source

Rated Output at 100% Duty Cycle

Spoolmatic: 200 A
XR-Pistol (air-cooled): 200 A
XR-Pistol (water-cooled): 400 A

Net Weight (Gun Only)

Spoolmatic: 2.9 lb. (1.3 kg)
XR-Pistol (air-cooled): 2.2 lb. (1 kg)
XR-Pistol (water-cooled): 2.4 lb. (1.1 kg)

Spoolmatic spool gun is available with 15- or 30-foot (4.6 or 9 m) cable lengths. The well-balanced industrial spool gun features a built-in gas valve, rotatable canister, and all-wire dual-groove drive roll.



Head tubes are FasTip™ and Bernard® Centerfire™ compatible. Head tube comes standard with FasTip consumables. (See page 4 for FasTip and optional Bernard consumables.)

Easy access to drive assembly and removable head tube reduces service time by allowing a simple means of changing drive rolls and head tube or performing routine maintenance without disassembly of gun.

Quick-change, single-turn contact tip provides excellent performance and ease of replacement.

Wire speed on gun handle and reversible drive rolls save time and money.

The **Spoolmatic** is designed to be used with the **WC-24, WC-115 weld control** or as a direct connect to select **Millermatic®** power sources.

A complete system consists of the following:

- **Spoolmatic spool gun**
(Includes .035–1/16 in. dual drive roll and two FasTip™ contact tips — .035 in. and 3/64 in.)
- **WC-24 or WC-115 weld control**
(Required unless using a machine that allows direct hookup.)
- **Recommended Miller® 14-pin power source or select Millermatic®** *(See page 6.)*

XR-Pistol push-pull gun is available in air- or water-cooled versions with 15- or 30-foot (4.6 or 9 m) cable lengths. The replaceable feed cable liner saves time and money, while the trigger hold, when paired with the XR-S Control or XR-AlumaFeed, eliminates hand strain. Also has a full leather cable cover with full length hook-and-loop closure for easy maintenance.



Replaceable feed cable liner reduces parts cost and service time by allowing a simple means of removing and replacing liner and not the complete feed cable. (XR-Pistol only.)

Trigger hold reduces fatigue by allowing operator to weld without holding trigger. (Feature only available when XR-Pistol is paired with XR-S Control or XR-AlumaFeed.)



The **XR-Pistol** is designed to be used with the **XR™-S Control** or **XR-AlumaFeed®** as part of a push-pull system.

A complete system consists of the following:

- **XR-Pistol push-pull gun**
- **XR-S Control or XR-AlumaFeed**
(See literature M/1.7 or DC/34.0.)
- **Recommended Miller® 14-pin power source or select Millermatic®** *(See page 7.)*



Guns are warranted for one year, parts and labor.



Miller Electric Mfg. LLC
An ITW Welding Company
1635 West Spencer Street
P.O. Box 1079
Appleton, WI 54912-1079 USA

Equipment Sales US and Canada
Phone: 866-931-9730
FAX: 800-637-2315
International Phone: 920-735-4554
International FAX: 920-735-4125

MillerWelds.com



Spoolmatic® Specifications (Subject to change without notice.)



Welding Current Rating	Wire Feed Speed	Wire Diameter Capacity	Maximum Spool Size Capacity	Gun Dimensions	Net Weight
200 A at 100% duty cycle	70–875 ipm (1.8–22.2 m/min.) dependent on control box or Millermatic used	Aluminum: .030–1/16 in. (0.8–1.6 mm) Hard Wire: .030–.045 in. (0.8–1.1 mm)	4 in. (102 mm)	H: 10.25 in. (260 mm) W: 2.5 in. (64 mm) L: 15.125 in. (384 mm)	Gun only: 2.9 lb. (1.3 kg) Gun with 15 ft. cable: 9 lb. (4.1 kg) Gun with 30 ft. cable: 14 lb. (6.4 kg)

Spoolmatic Air-Cooled Parts Breakdown

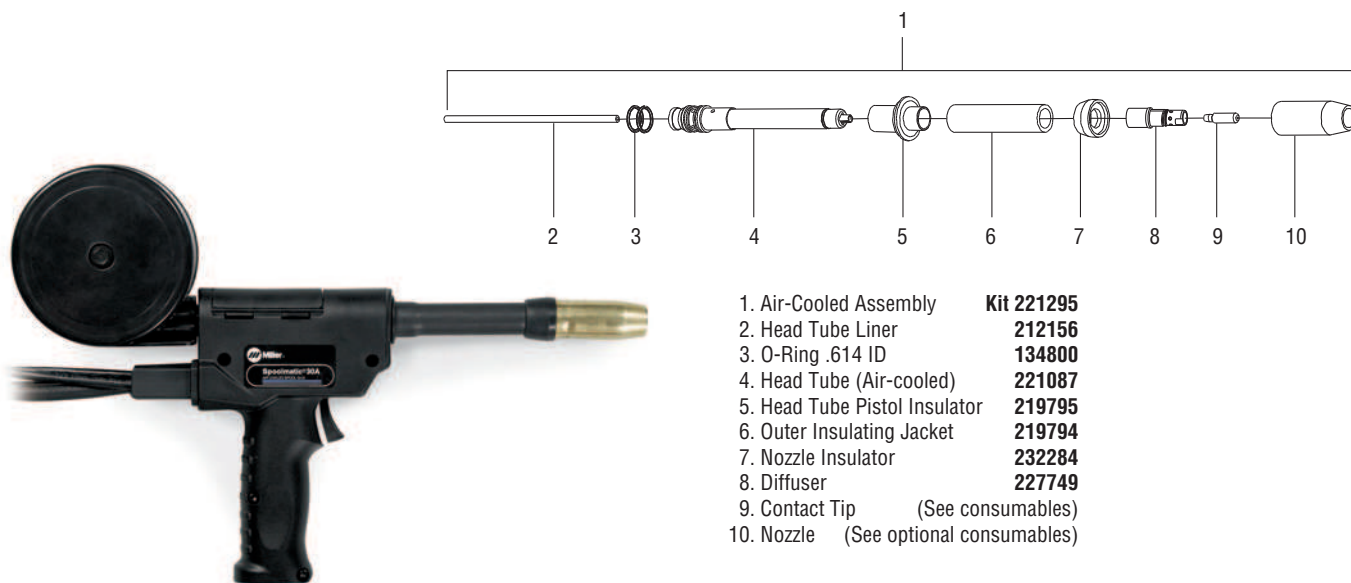

- 1. Air-Cooled Assembly **Kit 221295**
- 2. Head Tube Liner **212156**
- 3. O-Ring .614 ID **134800**
- 4. Head Tube (Air-cooled) **221087**
- 5. Head Tube Pistol Insulator **219795**
- 6. Outer Insulating Jacket **219794**
- 7. Nozzle Insulator **232284**
- 8. Diffuser **227749**
- 9. Contact Tip (See consumables)
- 10. Nozzle (See optional consumables)

Spoolmatic Standard Replacement Consumables

Aluminum Wire Size	FasTip™ Contact Tip (Qty. 25)	Drive Rolls	All-Wire Dual-Groove Drive Rolls	Head Tube Liner
.030 in. (0.8 mm)	206186 .041 in. ID	183357	136135	212156
.035 in. (0.9 mm)	206187 .047 in. ID	183357	136135	212156
.040 in. (1.0 mm)	206188 .053 in. ID	183357	136135	212156
3/64 in. (1.2 mm)	206189 .061 in. ID	183358	136135	212156
1/16 in. (1.6 mm)	206191 .071 in. ID	183358	136135	212156

Each gun is shipped with .035-inch and .047-inch standard tips.

XR™-Pistol Specifications (Subject to change without notice.)



Model	Welding Current Rating	Wire Feed Speed	Wire Diameter Capacity	Dimensions	Net Weight
XR-Pistol (air-cooled)	200 A at 100% duty cycle 250 A at 60% duty cycle	70–875 ipm (1.8–22.2 m/min.)	.030–1/16 in. (0.8–1.6 mm) aluminum wire	H: 7.375 in. (187 mm) W: 1.875 in. (48 mm) D: 10.625 in. (270 mm)	Gun only: 2.2 lb. (1 kg) Gun with 15 ft. cable: 13 lb. (5.9 kg) Gun with 30 ft. cable: 21 lb. (9.5 kg)
XR-Pistol (water-cooled)	400 A at 100% duty cycle				Gun only: 2.4 lb. (1.1 kg) Gun with 15 ft. cable: 14 lb. (6.4 kg) Gun with 30 ft. cable: 21.5 lb. (9.8 kg)

XR-Pistol Air-Cooled Parts Breakdown

1. Air-Cooled Assembly	Kit 231523
2. Water-Cooled Assembly	Kit 231524
3. Head Tube Liner	212156
4. O-Ring .614 ID	134800
5. Head Tube (Air-cooled)	221087
Head Tube (Water-cooled)	221519
6. Head Tube Pistol Insulator	219795
7. Outer Insulating Jacket	219794
8. Nozzle Insulator	232284
9. Diffuser	227749
10. Contact Tip	(See consumables)
11. Nozzle	(See optional consumables)

XR-Pistol Standard Replacement Consumables (Air-cooled only.)

Aluminum Wire Size	FasTip™ Contact Tip (Qty. 25)	Drive Rolls	All-Wire Dual Groove Drive Rolls	Head Tube Liner	Cable Liners
.030 in. (0.8 mm)	206186 .041 in. ID	183357	136135	212156	191065 15 or 30 ft. (4.6 or 9 m)
.035 in. (0.9 mm)	206187 .047 in. ID	183357	136135	212156	
.040 in. (1.0 mm)	206188 .053 in. ID	183357	136135	212156	
3/64 in. (1.2 mm)	206189 .061 in. ID	183358	136135	212156	
1/16 in. (1.6 mm)	206191 .071 in. ID	183358	136135	212156	

Standard Consumables – FasTip™ Series

Gas Diffusers



227749 1/8 in. tip recess (Standard)
For heavy-duty FasTip contact tips.

231511 1/4 in. tip recess
For heavy-duty FasTip contact tips.

231512 Flush tip
For heavy-duty FasTip contact tips.

FasTip Contact Tips (25 per package)



Heavy-Duty (Aluminum Wire)

206186 .030 in. (0.8 mm)

206187 .035 in. (0.9 mm)

206188 .040 in. (1.0 mm)

206189 3/64 in. (1.2 mm)

206191 1/16 in. (1.6 mm)

Tapered (Aluminum Wire)

209026 .030 in. (0.8 mm)

209027 .035 in. (0.9 mm)

209029 3/64 in. (1.2 mm)

206030 1/16 in. (1.6 mm)

Nozzles

Screw-On Brass

199610 1/2 in. orifice, tapered

199611 3/4 in. orifice, straight HD

199612 3/4 in. orifice, straight HD

199613 5/8 in. orifice, tapered

199614 5/8 in. orifice, tapered HD

Screw-On Copper

199615 1/2 in. orifice, tapered

199616 3/4 in. orifice, straight

199617 3/4 in. orifice, straight HD

198855 5/8 in. orifice, tapered

199618 5/8 in. orifice, tapered HD

207313 5/8 in. orifice, tapered 15/16 O.D.

209035 3/8 in. orifice, tapered

209036 1/2 in. orifice, tapered

Optional Consumables – Centerfire™ Series

Insulator 10012
4323R

Diffuser D-1 (large)
DS-1 (small)

Aluminum-Specific T Series Contact Tips

T-035AL .035 in. (0.9 mm)

T-047AL .047 in. (1.2 mm)

T-062AL 1/16 in. (1.6 mm)

T Series Contact Tips

for Hard or Cored Wires 1.5 in. (38.1 mm)

T-030 .030 in. (0.8 mm)

T-035 .035 in. (0.9 mm)

T-039 .039 in. (1.0 mm)

T-045 .045 in. (1.2 mm)

T-052 .052 in. (1.4 mm)

T-062 1/16 in. (1.6 mm)

TT Series Contact Tips

for Hard or Cored Wires 2 in. (50.8 mm)

TT-030 .030 in. (0.8 mm)

TT-035 .035 in. (0.9 mm)

TT-045 .045 in. (1.2 mm)

TT-052 .052 in. (1.4 mm)

TT-062 1/16 in. (1.6 mm)

Large Nozzles

N-3414C Copper, 3/4 in. I.D., 1/4 in. tip recess

N-3418B Brass, 3/4 in. I.D., 1/8 in. tip recess

N-3414B Brass, 3/4 in. I.D., 1/4 in. tip recess

N-5814C Copper, 5/8 in. I.D., 1/4 in. tip recess

N-5818B Brass, 5/8 in. I.D., 1/8 in. tip recess

N-5814B Brass, 5/8 in. I.D., 1/4 in. tip recess

Small Nozzles

NS-5818B Brass, 5/8 in. I.D., 1/8 in. tip recess

NS-1218B Brass, 1/2 in. I.D., 1/8 in. tip recess

NS-1200B Brass, 1/2 in. I.D., flush tip

NST-3818B Brass, 3/8 in. I.D., 1/8 in. tip recess

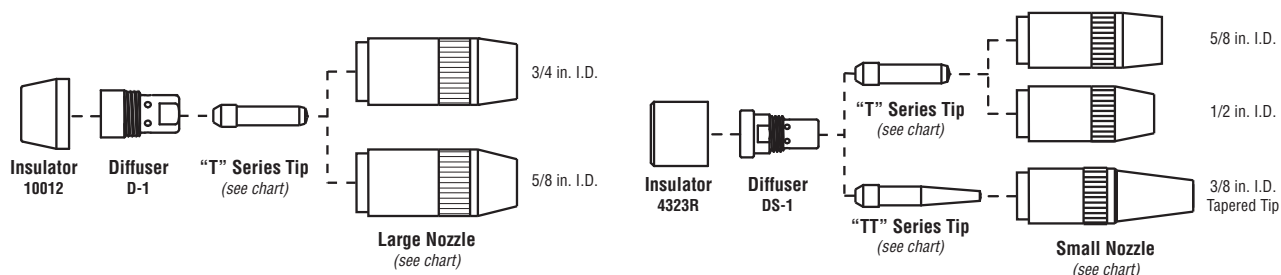

Genuine Miller® Accessories

Hose and Cable Extension Kits

132228 25 ft. (7.6 m)
132229 50 ft. (15 m)

Extends Spoolmatic® away from the control box. Convenient plug-in connections. Includes gas hose, control cord, and weld power cable with insulated connector. *For Spoolmatic only.*

Hardwire Liner Kit for Steel and Stainless 198377

For 15 or 30 ft. (4.6 or 9 m) guns. Kit consists of gun head tube liner and feed cable liner. Recommend using .030–.045 inch mild steel or stainless steel electrode wire. *For XR™-Pistol only.*

Note: .052- and 1/16-inch wires not recommended.

Leather Cable Cover

241159 15 ft. (4.6 m)
241160 30 ft. (9 m)

Protects gun hose and cable assembly from wear and abrasion. Features full-length hook-and-loop closure for ease of maintenance or replacement.



One-Pound (0.5 kg) Spool Canister 132230

Ideal for use with XR guns if a small job arises requiring a different wire size and/or wire type that does not justify a 12-inch (305 mm) spool of wire. The XR feed cable is removed if the spool canister is being used. Canister accommodates 4-inch (102 mm) spools of wire.

Air-Cooled Head Tubes

For Spoolmatic and XR-Pistol.



50-Degree Curved Head Tube-A

222462 *For FasTip™ consumables*
6-inch (152 mm). Used with .030–1/16 inch (0.8–1.6 mm) wire. Kits supplied with liner that accommodates all wire sizes.



10-Inch Flex Head-A 222735

For .030–1/16 inch (0.8–1/6 mm) wire. Used in place of the standard straight head tube. Flexible head tube bends 60 degrees in any direction for easier joint access and improved operator comfort. Supplied with liners. Uses FasTip contact tips.



10-Inch Head Tube-A 222461

Ideal when a longer reach is required.

Replacement Liners for Air-Cooled Head Tubes

For 50-Degree Curved Head Tube
212411 .030–1/16 in. (0.8–1.6 mm)

For 10-Inch Flex Head
222853 .030–.035 in. (0.8–0.9 mm)
222854 .047–.062 in. (1.2–1.6 mm)

For 10-Inch Straight Head Tube
212401 .030–1/16 in. (0.8–1.6 mm)

50-Degree Curved Nozzle Kit-A

147174 For old-style multi-piece head tubes
300161 For newer Roughneck®-style head tubes
Attaches to gun head tube assembly for access to confined weld joint areas. Used with .030–1/16 inch (0.8–1.6 mm) wire. Kit includes two of each size contact tips to accommodate all wire sizes, nozzle adapter kit and curved nozzle. Uses standard straight head tube liner.

Replacement Contact Tips for 50-Degree Curved Nozzle

148155 .030 and .035 in. (0.8 and 0.9 mm) wire
148154 .047 in. (1.2 mm) wire
148156 1/16 in. (1.6 mm) wire

Water-Cooled Head Tubes

For XR-Pistol only.



50-Degree Curved Head Tube-W 222464

6-inch (152 mm). Used with .030–1/16 inch (0.8–1.6 mm) wire. Kits supplied with liner that accommodates all wire sizes.

Replacement Liners for Water-Cooled Head Tubes

For 50-Degree Curved Head Tube
212411 .030–1/16 in. (0.8–1.6 mm)

For 10-Inch Straight Head Tube
212401 .030–1/16 in. (0.8–1.6 mm)

Typical Spoolmatic® Installations

Note: Cords and cables are supplied unless noted otherwise on drawings below. Refer to Owner's Manual for complete installation instructions.

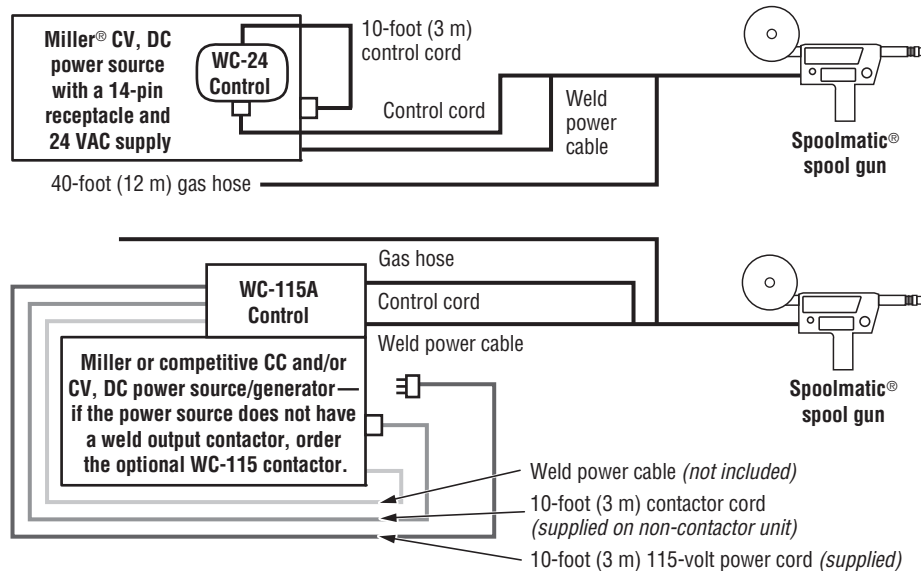

Spoolmatic Spool Gun Hook-Up Recommendations

CV Power Supply	Spoolmatic
Millermatic® Vintage*	Need Module 043084
Millermatic® DVI™*, DVI ₂ ™*, 210*, 212*	Need Adapter Cable 195287 (WFS controlled at machine)
Millermatic® 212 Auto-Set™, 250X*, 251*, 252, 255, 300 w/meters*, 350*, 350P, Multimatic® 255, Shopmate™ 300 DX*	Direct Hook-Up
AlumaPower™ MPa, CP Series, Deltaweld® Series, Dimension™ Series, Invision™ Series, Regency® 250*, Shopmaster™*, XMT® Series, PipePro® 304*, Trailblazer® Series	Need WC-24 137549
Bobcat™ 200 Air Pak™	Direct Hook-Up
Bobcat™ Series, Miller Legend® 302*	Need WC-115A 137546011

*Discontinued product.



WC-115A Weld Control

137546 Without contactor
137546011 With contactor
 Operates on 115-volt power and designed primarily for constant-current DC power sources. Can also be used with constant-voltage power sources or DC engine drives supplying 115 volts. Used with a CC source the control circuit functions in a voltage-sensing mode, and with a CV source it functions as a constant-speed circuit.



WC-24 Weld Control 137549

Packaged in a compact, lightweight, non-metallic enclosure, the WC-24 easily mounts directly on the power source. Designed for use with Miller constant-voltage power sources with 14-pin receptacles and supplying 24 VAC. The control includes a board-mounted potentiometer which can alter the drive motor acceleration rate to optimize arc starting performance.

Important note:

To connect the Spoolmatic gun and WC-24 control to older-style Miller® or competitive CV power sources that do **NOT** have a 24 VAC supply, the PSA-2 Control **141604** is required.

Standard features include a wire run-in control and a drive motor acceleration control which ensure optimum arc starting performance, regardless of the type of power source being used. The WC-115A comes with a 10-foot (3 m), wall-type plug power cord.

Important notes:

To connect the WC-115A control to older-style Miller power sources having Hubbell or 5-pin contactor control receptacles, the appropriate connector must be ordered separately.

To connect to older-style Miller CC power sources having a two-socket Hubbell connector, order plug **039618**.

If power source has a Miller 5-pin receptacle, order **039273** and **039685**.

To connect to older-style Miller CV power sources having a two-prong Hubbell connector, order plug **039635**.

These connectors are to replace the 14-pin connector on the 10-foot interconnect contactor cord. Internal wiring changes may be necessary.

Typical XR™-Pistol Installations

Note: Cords and cables are supplied unless noted otherwise on drawings below. Refer to Owner's Manual for complete installation instructions.

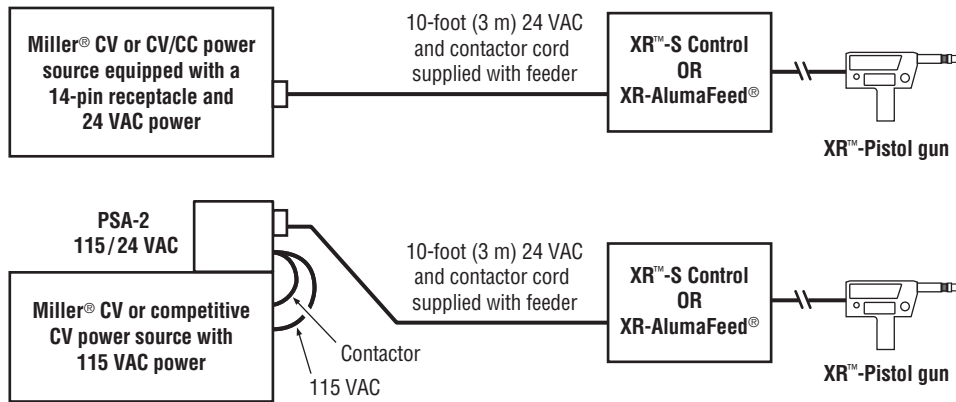

XR-Pistol Gun Hook-Up Recommendations

CV Power Supply	Control
Millermatic® 252, 350P, 350P Aluminum	Direct Hook-Up
AlumaPower™ 350 MPa, 450 MPa Deltaweld® Series Dimension™ Series Invision™ Series XMT® Series (except VS model) Trailblazer® 325, 302 Air Pak™ Big Blue® Series (with 14-pin receptacle)	XR™-S Control or XR-AlumaFeed®



XR™-S Control 300601

The XR-S Control offers unsurpassed performance and reliability for feeding aluminum and other difficult-to-feed wire types. Model includes .035-inch and factory-installed 3/64-inch drive rolls. See literature M/1.7.



XR-AlumaFeed® Wire Feeder 300509

Advanced push-pull wire feeder designed for high-volume, high-production aluminum MIG welding where quality and consistency is a high priority. See literature DC/34.0.

Ordering Information

Important notes:

Spoolmatic guns require a WC-24 or WC-115 weld control, unless used on a machine that allows direct hookup. Refer to chart on page 6.

XR-Pistol Grip Guns require an XR-S Control or XR-AlumaFeed, or may be direct connected to a Millermatic® 252, 350P, or 350P Aluminum.

XR-Control must be serial number KK309906 or higher to be used with products and descriptions mentioned in this literature. To confirm a product's compatibility with older equipment, please contact the factory at 1-920-735-4505.

Equipment	Stock No.	Description	Qty.	Price
Spoolmatic® Spool Gun	195156	15 ft. (4.6 m) cable		
	130831	30 ft. (9 m) cable		
WC-24 Weld Control	137549	For Spoolmatic guns		
WC-115A Weld Control	137546	Without contactor. For Spoolmatic guns		
	137546011	With contactor. For Spoolmatic guns		
XR™-Pistol Push-Pull Gun (Air-Cooled)	198127	15 ft. (4.6 m) cable		
	198128	30 ft. (9 m) cable		
XR™-Pistol Push-Pull Gun (Water-Cooled)	198129	15 ft. (4.6 m) cable		
	198130	30 ft. (9 m) cable		
XR™-S Control (See literature M/1.7)	300601	Standard model includes .035 and 3/64 in. drive rolls, wire feed speed digital display, jog/purge, run-in control, and trigger hold		
XR-AlumaFeed® (See literature DC/34.0)	300509	Advanced model includes .035 and 3/64 in. drive rolls, and adds Profile Pulse™, synergic control, trigger schedule select, lock capabilities and flowmeter		
XR-Control/AlumaFeed Drive Roll	195591	1/16 in (1.6 mm)		
Consumables and Accessories				
Consumables		See pages 2–5		
Hose and Cable Extension Kits	132228	25 ft. (7.6 m). Spoolmatic only		
	132229	50 ft. (15 m). Spoolmatic only		
Hardware Liner Kit for Steel and Stainless	198377	For 15 or 30 ft. (4.6 or 9 m) guns. XR-Pistol only		
Leather Cable Cover	241159	15 ft. (4.6 m)		
	241160	30 ft. (9 m)		
One-Pound Spool Canister	132230			
Head Tubes		See page 6		
Coolant Systems		See literature AY/7.2		

Date:

Total Quoted Price:

Distributed by:

