

Product Data Sheet



LH-GTH 175K-FI

EAN 4047526626068

ID 626069

Pressed steel swivel castor, heavy duty castors, with top plate fitting and 'stop-fix' brake, Heavy duty wheel with Blickle Extrathane® polyurethane tread, with cast iron wheel centre

Bracket:

Made of heavy pressed steel, with heavy fork and top plate, very strong bolted and secured central kingpin, double ball bearing in the swivel head, additionally reinforced by the integration of four specially shaped and hardened bearing seats resulting in a very high resistance to shock and impact loads. Bolted wheel axle. Bolted wheel axle. Zinc-plated, blue-passivated, Cr6-free.

Wheels:

Made of high-quality, reaction-injected polyurethane-elastomer Blickle Extrathane®, low-noise operation, low rolling resistance, good floor preservation, very high abrasion resistance, high cut and tear propagation resistance, very good chemical connection with the wheel centre.

Tread colours: light brown

Wheel centre/rim: Made of grey cast iron, lacquered. Casted tread.

Wheel centre colour: silver

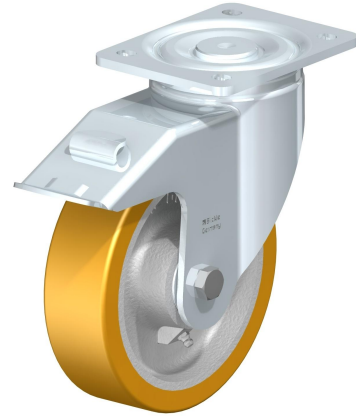

Rolling resistance

■■■■□ Very good

Operating noise

■■■■□ Good

Floor surface preservation

■■■■□ Good

Product Data Sheet



Technical data

Plate size		140 x 110
Bolt hole spacing		105 x 75-80
Bolt hole Ø		11
Wheel Ø		175 mm (D)
Wheel width		50 mm (T2)
Load capacity		875 kg
Total height		220 mm (H)
Offset swivel castor		67 mm
unit weight		6,7 kg
Temperature resistance to		-25 ° C
Temperature resistance to		70 ° C
tread and tyre hardness		92° Shore A
Bearing type		Ball bearing

