

Big Blue® 450 Duo CST™

**Diesel Engine-Driven
Welder/AC Generator**



Quick Specs



Industrial Applications

Pipe Welding
Structural
General Fabrication
Maintenance and Repair
Rental Fleets

Processes

Stick (SMAW)
DC TIG (GTAW) Lift-Arc™
Air Carbon Arc (CAC-A)
Rated: 3/16 in. (4.8 mm) carbons (paralleled)

Output Range

DC Stick/TIG 5–280 A (separate)
10–450 A (paralleled)

Max. Open-Circuit Voltage 77 V

Generator Output Rated at 104° F (40° C)

3-Phase 12,000 Watts continuous

1-Phase 10,000 Watts continuous

**Accu-Rated™—Not Inflated
Generator Power**

The Big Blue 450 Duo CST is a rugged, compact, fuel-efficient diesel welder/generator that provides two superior arcs in one economical package.

BUILT TOUGH

Superior Stick arc performance even on the difficult-to-run electrodes like E6010.

Adaptive Hot Start™ for Stick arc starts automatically increases the output amperage at the start of a weld should the start require it. Prevents the electrode from sticking and creating an inclusion.

Lift-Arc™ start provides TIG arc starting without the use of high frequency.

Remote amperage control provided through 14-pin receptacle on front of the machine. This permits use of standard remote amperage control devices.

Vandalism lockout kit. Lockable hinged steel panel protects front control panels and ignition switch.



USA model shown.



**MITSUBISHI ENGINE
NORTH AMERICA, INC.**

Mitsubishi S4L2 diesel engine. Used in industrial applications around the world, the S4L2 is designed to run 10,000 hours before major overhaul.

Meter maintenance displays.

- Hour meter function
- Oil change interval
- High coolant temperature and low oil pressure shutdowns
- Low fuel shutdown—engine shuts down before system runs out of fuel, making restarts easy.

Quiet operation. At just 72.2 decibels at 23 feet (7 m), it's quieter than most single-operator models, improving jobsite communication and safety.

Thermal overload protection prevents machine damage if the duty cycle is exceeded or airflow is blocked.

High efficiency. Three-phase, rotating-field generator requires less fuel and horsepower to operate.

See page 3 for more machine features/benefits.



Welder/generator is warranted by Miller for 3 years, parts and labor.
Engine is warranted separately by engine manufacturer.



Miller Electric Mfg. Co.
An ITW Welding Company
1635 West Spencer Street
P.O. Box 1079
Appleton, WI 54912-1079 USA

Equipment Sales US and Canada
Phone: 866-931-9730
FAX: 800-637-2315
International Phone: 920-735-4554
International FAX: 920-735-4125

MillerWelds.com
Facebook, Twitter, YouTube, Instagram icons



Specifications (Subject to change without notice.)



Weld Mode/ Process	Output Mode	Weld Output Range	Weld Output Rated at 122° F (50° C)	Max. Open-Circuit Voltage	Generator Power Output Rated at 122 F (50° C)	Sound Levels at Rated Output, 23 ft. (7 m)	Dimensions	Weight (without fuel)*
CC/DC (Stick/TIG)	Separate (dual outputs)	5–225 A (each side) 5–280 A (one side only)	USA Model 175 A, 27 VDC, 100% duty cycle International Model 200 A, 28 VDC, 100% duty cycle	77	3-phase: 12,000 watts, 240 VAC, 60 Hz continuous 1-Phase: 10,000 watts, 120/240 VAC, 60 Hz continuous	72.2 dB (97 Lwa)	H: 32 in. (813 mm) W: 26.25 in. (667 mm) D: 56 in. (1422 mm)	Net: 1064 lb. (483 kg) Ship: 1114 lb. (505 kg)
	Paralleled (combined)	10–450 A	USA Model 350 A, 27 VDC, 100% duty cycle International Model 400 A, 28 VDC, 100% duty cycle					

*Additional 95 lb. (43 kg) when fuel tank is full.

 Certified by Canadian Standards Association to both the Canadian and U.S. Standards. Meets NEMA and IEC output ratings.

Engine Specifications (Engines warranted separately by the engine manufacturer.)

Engine Brand	Features	HP	Type	Engine Speeds	Capacities	Automatic Engine Shutdown
Mitsubishi S4L2	EPA Tier 4 Final compliant	24.7	Four-cylinder, liquid-cooled industrial diesel	Weld: 1800 RPM	Fuel: 11.5 gal. (43.5 L) Oil: 6.3 qt. (6 L) Coolant: 10 qt. (9.5 L)	Low oil pressure, high coolant temperature, low fuel level

Performance Data

FUEL CONSUMPTION CURVE

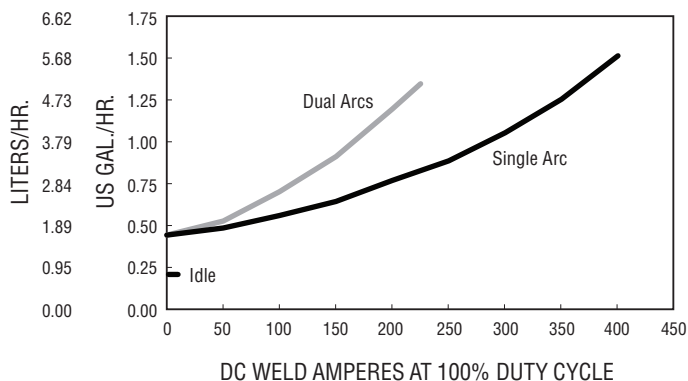

SIMULTANEOUS WELDING AND POWER

Weld Amperes	Total 1-Phase Aux. Power Available (Watts)
No Weld Output	10,000
200 A	5,200
300 A	2,700
400 A	0

Function Guide

1. Output Light
2. On/Off Switch
3. Weld Process Selector Switch
4. Overtemp Light
5. Amperage Adjustment Control (5–280 Amps)
6. Standard 14-pin Receptacle for simple connection of remote controls and wire feeders. It features **Auto Remote Sense™** which automatically switches from panel to remote amperage/voltage (A/V) control with remote connected. Eliminates confusion of the panel/remote A/V switch.
7. Negative (–) Weld Output Terminal
8. Glow Plugs assist in cold weather starting.
9. Meter Maintenance Displays show fuel level, engine hours, oil change interval and high temp/low pressure/low fuel shutdown information.
10. Engine Control Switch is used to start and stop the engine and select power range.

USA Model Receptacles and Circuit Breakers

11. 120/240 V, 50 A, AC Receptacle
Note: For matching plug, order #119 172.
12. 120 and 240 V Circuit Breakers
13. 120 V, 20 A, AC Receptacles with Ground Fault

International Model Receptacles and Circuit Breakers

14. 120 V, 20 A, AC Receptacles with Ground Fault
15. 240 V Earth Leakage Circuit Breaker
16. 120 V Circuit Breakers
17. 120 V/16 A and 240 V/16 A, AC Receptacles

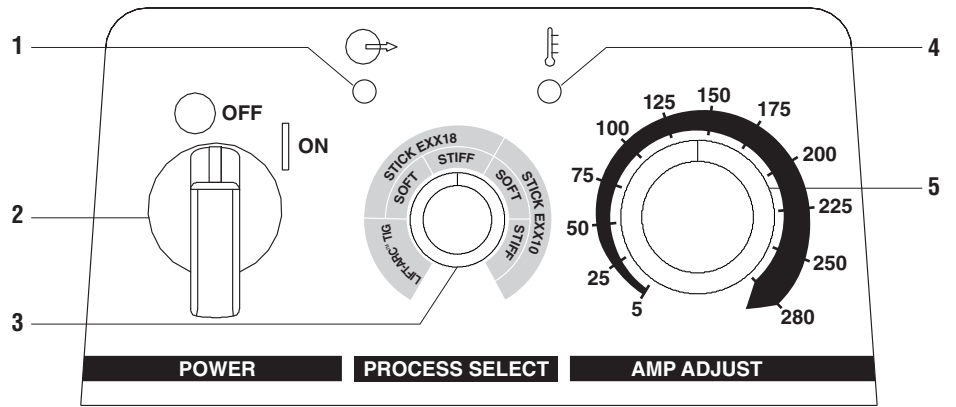

See top panel for feature callouts

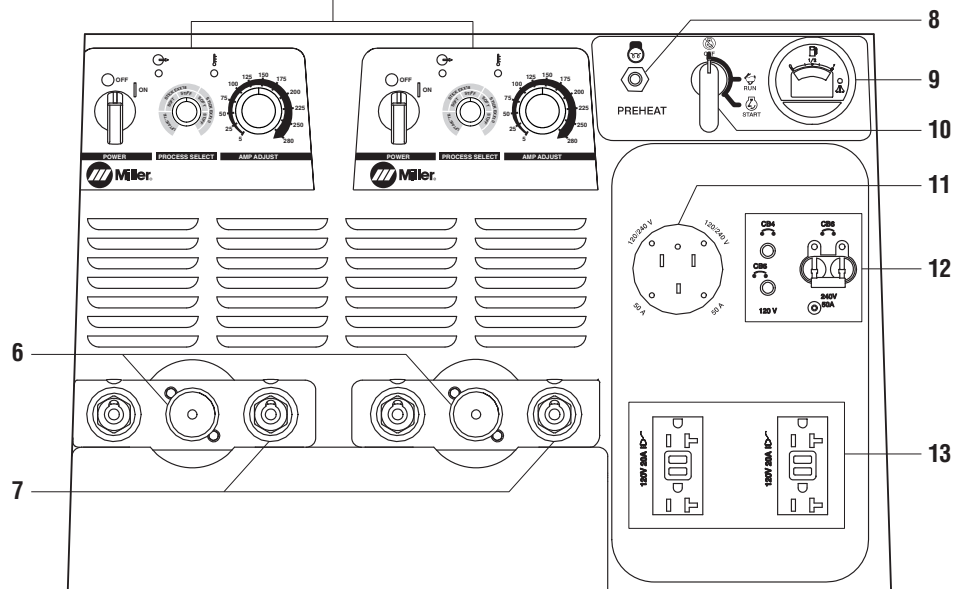

USA Model

See top panel for feature callouts

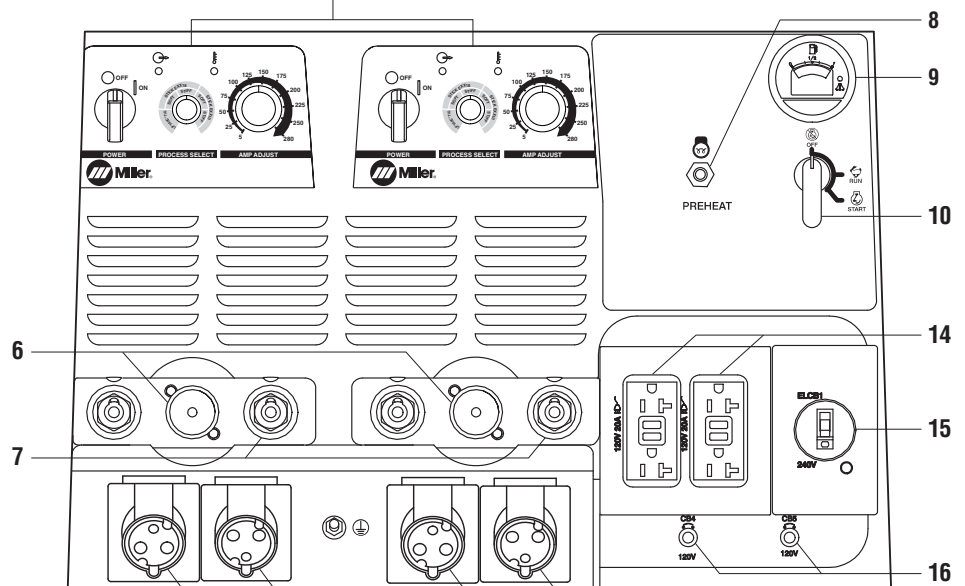

International Model

Genuine Miller® Accessories



USA Model Full KVA Plug Kit #119 172 Field
1-phase, 120/240 VAC, 50 A plug (NEMA 14-50P) to fit full KVA receptacle.



International Plugs Field
#255 419 1-Phase, 120 VAC, 16 A plug
#255 416 1-Phase, 240 VAC, 16 A plug

Cold Weather Starting Kit #300 664 Field
120 V block heater.

Note: All models come standard with preheaters (glow plugs).

Engine Filter Kit #252 782 Field
Includes all filters required for proper engine maintenance. Oil filter, primary and secondary fuel filter, and primary air filter.

Spark Arrestor (Muffler) Kit #300 585 Field
Prevents particles from leaving the muffler that could potentially start a fire.



FA-1D Lockable Flame Arrestor Fuel Cap #043 947 Field

Fuel cap can be padlocked to prevent vandalism. A built-in flame arrestor prevents flames

or sparks from entering the fuel tank.

Chalwyn Safety Valve #300 576 Field
Shuts off air flow to the engine to prevent over-speed condition. Required on many petroleum jobsites, this valve provides both manual and automatic operation giving you two methods of operation to meet jobsite compliance standards.



Protective Cover #195 301 Field
Blue water-resistant cover with Miller logo resists stains and mildew, and protects the finish of your welder.

Stick (SMAW) Welding

Weld Leads

No. 2 Stick Cable Set, 15 ft. (4.6 m) #195 196

Consists of 15-foot (4.6 m) No. 2 electrode cable with holder, and 15-foot (4.6 m) work cable with clamp. 200 A, 100% duty cycle.

No. 2 Stick Cable Set, 50 ft. (15 m) #300 836

Consists of 50-foot (15 m) No. 2 electrode cable with holder, and 50-foot (15 m) work cable with clamp. 200 A, 100% duty cycle.

2/0 Stick Cable Set, 50 ft. (15 m) #173 851

Consists of 50-foot (15 m) 2/0 electrode cable with holder, and 50-foot (15 m) work cable with clamp. 350 A, 100% duty cycle.

2/0 Stick Cable Set, 100/50 ft. (30.5/15 m) #043 952

Consists of 100-foot (30.5 m) 2/0 electrode cable with holder, and 50-foot (15 m) work cable with clamp. 300 A, 100% duty cycle.

TIG (GTAW) Torches



Weldcraft® TIG Torches

The Weldcraft line of TIG torches complements the most popular TIG power source line available today. The Weldcraft torch line includes both air-cooled and water-cooled models. Available with genuine Weldcraft parts.

#WP-17V-12-2 150 A, 12 ft. (3.7 m) air-cooled torch with valve, two-piece cable.

#WP-17V-25-2 150 A, 25 ft. (7.6 m) torch with valve, two-piece cable.

#WP-26V-25-2 200 A, 25 ft. (7.6 m) air-cooled torch with valve.

These two-cable TIG torches require the installation of a Dinse-Style Connector (#042 418) or Tweco-Style Connector (#195 115) depending on the CST model connector type.

Plasma Cutting



Spectrum® 375 X-TREME™ #907 529
See Lit. Index No. PC/9.2.

Spectrum® 625 X-TREME™ #907 579 with 12-foot (3.7 m) torch
#907 579 001 with 20-foot (6 m) torch
See Lit. Index No. PC/9.6.

The Spectrum 375 X-TREME and 625 X-TREME come complete with protective X-CASE™ (not shown).

Genuine Miller® Accessories (Continued)

Remote Controls



Wireless Remote Hand Control* #300 430

For remote current control. Receiver plugs directly into the 14-pin receptacle of Miller machine. 300-foot (91.4 m) operating range. Requires Wireless Antenna Kit #300 749.



Wireless Remote Foot Control* #300 429

For remote current control. Receiver plugs directly into the 14-pin receptacle of Miller machine. 90-foot (27.4 m) operating range. Requires Wireless Antenna Kit #300 749.

Wireless Antenna Kit #300 749

Required for Pro Series engine drives. Optional on other compatible Miller products where improved reception is desired.



PRHC-14 Hand Control* #195 511

Complete current control brings 120 volts GFCI power to work area in a single cord. Housed in a durable light aluminum case and includes 125-foot (38 m) cord with plugs.



RHC-14 Hand Control* #242 211 020

Miniature hand current control. Dimensions: 4 x 4 x 3.25 inches (102 x 102 x 82 mm). Includes 20-foot (6 m) cord and 14-pin plug.



RCC-14 Remote Current Control* #151 086

East/west rotary-motion fingertip control attaches to TIG torch using two hook-and-loop fasteners. Includes 26.5-foot (8 m) cord and 14-pin plug.



RCCS-14 Remote Current Control* #043 688

North/south rotary-motion fingertip control attaches to TIG torch using two hook-and-loop fasteners. Includes 26.5-foot (8 m) cord and 14-pin plug.



RFCS-14 HD Foot Control* #194 744

Heavy-duty foot current control. Includes 20-foot (6 m) cord and 14-pin plug.

Extension Cables for 14-Pin Remote Controls

- #242 208 025 25 ft. (7.6 m)
- #242 208 050 50 ft. (15.2 m)
- #242 208 080 80 ft. (24.4 m)

**Controls only amperage on the Big Blue 450 Duo CST—electrode always hot.*

Cable Connectors and Adapters

Dinse-Style Connector #042 418

Accepts #4 to #1/0 AWG cable size. Required if male plugs shipped with power source must be replaced or if additional plugs are needed. Kit includes one Dinse-style male plug which attaches to the work and/or weld cables and plugs into the Dinse-style receptacles on the power source.

Extension Kit for Dinse-Style Cable Connectors #042 419

Accepts #4 to #1/0 AWG cable size. Used to adapt or extend weld and/or work cables. Kit includes one male Dinse-style plug and one in-line female Dinse-style receptacle.



Dinse/Tweco® Adapter #042 465

A one-piece adapter which has a Dinse-style male plug (to power source) on one end and a female Tweco receptacle (for weld cable connection) on other end.



Dinse/Cam-Lok Adapter #042 466

A one-piece adapter which has a Dinse-style male plug (to power source) on one end and a Cam-Lok receptacle (for weld cable connection) on other end.



Tweco-Style Connector #191 981

Accepts #1/0 to #2/0 AWG cable size. Kit includes one Tweco-style male plug which attaches to the work and/or weld cables and plugs into the receptacle on the power source.



Tweco/Dinse Adapter #210 061

A one-piece adapter which has a Tweco-style male plug (to power source) on one end and a female Dinse-style receptacle (for weld cable connection) on other end.

Trailers and Hitches (Note: Trailers are shipped unassembled.)



HWY-224 Trailer #043 805

A 2650-pound (1202 kg) capacity trailer for highway use. Welded steel tubing frame, heavy-duty axle with roller bearing hubs and leaf-spring suspension. Includes jack stand, 2-inch (50 mm) ball hitch, fenders and lights.

Cable Tree #043 826

Provides an area to conveniently wrap weld cables and extension cords.



Dual Hitch #300 831

2-inch (50 mm) ball hitch and 3-inch (76 mm) lunette eye in one reversible assembly.

Mounting Specifications

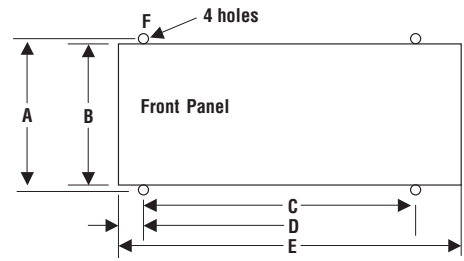

- A. 27.75 in. (705 mm)
- B. 26.25 in. (667 mm)
- C. 52 in. (1321 mm)
- D. 2 in. (51 mm)
- E. 56 in. (1422 mm)
- F. .562 in. (14 mm) diameter

Height: 32 in. (813 mm)
Width: 26.25 in (667 mm)
Depth: 56 in. (1422 mm)

Trailer Specifications (Subject to change without notice.)

Model	Gross Axle Weight Rating	Gross Vehicle Weight Rating	Net Payload	Height of Bed	Road Clearance	Track (Center to center of tires)	Standard Tires (Standard rating or P-size rating)	Dimensions	Net Weight
HWY-224	3500 lb. (1588 kg)	2960 lb. (1343 kg)	2650 lb. (1202 kg)	18.5 in. (470 mm)	7.25 in. (184 mm)	52 in. (1321 mm)	B78-13	Length: 105 in. (2667 mm) Width: 59.5 in. (1511 mm)*	320 lb. (145 kg)

*Width at outside of fenders.

What Makes Miller® Industrial Engine Drives So [TOUGH]?

Rigorous Testing for Tough, Real-World Conditions

To prove our machines go to the limit, Miller industrial engine drives are put to the test in very extreme environmental conditions.

- **Airborne dust and sand.**

Critical components are exposed to abusive airborne particles in a special testing chamber for weeks, helping make sure they'll operate while facing extreme levels of dirt, dust or sand on the jobsite.

- **Humidity and corrosion.**

Inside our Houston testing room, critical components are subjected to extended moisture and corrosive salt exposure to ensure they'll run even when exposed to humid climates, corrosive coastal environments, and driving rain.

- **Temperature extremes.** Miller industrial engine drives are tested to ensure performance in scorching heat. All Miller engine-driven machines are weld rated at 104 degrees Fahrenheit, but actual tests are conducted up to 122 degrees Fahrenheit to assure peak performance.



- **Jobsite/over-the-road abuse.** Miller industrial engine drives are shaken for hours on transportation bed simulators, subjected to severe vibration, and test-dropped and jerked to ensure they'll withstand the stresses that can shut down competitive machines.

- **Continuous operation.** Miller industrial engine drives run day and night, in all weather conditions, to assure they'll perform without interruption in the field.



Why Industrial Engine Drive Customers Choose Miller

The ultimate test of Miller reliability is how it performs in the field. Read stories demonstrating our superior reliability at MillerWelds.com.

Typical Installations

Electrode Hot



Stick (SMAW) Basic Equipment

PRHC-14 #195 511

Wireless Remote Hand Control #300 430

Note: Illustration at right shows single arc installation. For dual arc installations, two sets of cables, two remote controls and two electrode holders are needed.

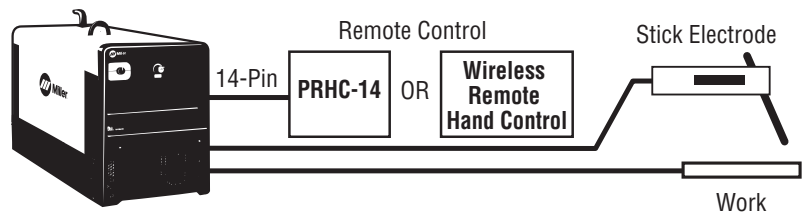

Lift-Arc™ TIG (GTAW) Basic Equipment

Note: Illustration at right shows single arc installation. For dual arc installations, two sets of cables and two TIG torches are needed.

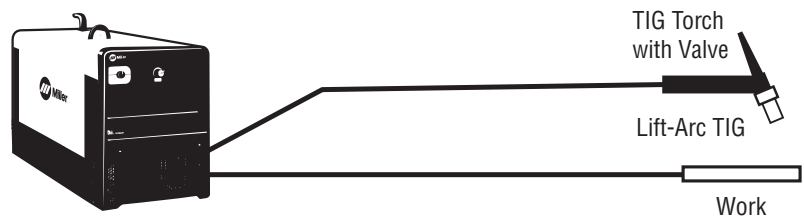

Ordering Information

Equipment and Options	Stock No.	Description	Qty.	Price
Big Blue® 450 Duo CST™	#907 477	USA model with Tweco®-style connectors		
Big Blue® 450X Duo CST™	#907 473	International model with Dinse-style connectors		
	#907 473 001	International model with Dinse-style connectors and VRD		
Field Accessories				
USA Model Full KVA Plug Kit	#119 172	1-phase, 120/240 VAC, 50 A		
International Plugs	#255 419 #255 416	1-phase, 120 V, 16 A 1-phase, 240 V, 16 A		
Cold Weather Starting Kit	#300 664	120 V block heater		
Engine Filter Kit	#252 782	Includes air, oil and fuel filters		
Spark Arrestor Kit	#300 585			
FA-1D Lockable Flame Arrestor Fuel Cap	#043 947			
Chalwyn Safety Valve	#300 576			
Protective Cover	#195 301			
Stick Welding Leads				
		See page 4		
Weldcraft® TIG Torches				
		See page 4		
Plasma Cutting				
Spectrum® 375 X-TREME™	#907 529	Includes X-CASE™ See Lit. Index No. PC/9.2		
Spectrum® 625 X-TREME™	#907 579 #907 579 001	With 12-ft. (3.7 m) torch and X-CASE™ See Lit. Index No. PC/9.6 With 20-ft. (6 m) torch and X-CASE™ See Lit. Index No. PC/9.6		
Remote Controls				
Wireless Remote Hand Control	#300 430	Amperage control only — electrode always hot		
Wireless Remote Foot Control	#300 429	Amperage control only — electrode always hot		
Wireless Antenna Kit	#300 749	Required for wireless remotes when using Pro Series engine drives		
PRHC-14 Hand Control	#195 511	Amperage control only — electrode always hot		
RHC-14 Hand Control	#242 211 020	Amperage control only — electrode always hot		
RCC-14 Remote Current Control	#151 086	Side-to-side rotary amperage control only — electrode always hot		
RCCS-14 Remote Current Control	#043 688	Up-and-down rotary amperage control only — electrode always hot		
RFCS-14 HD Foot Control	#194 744	Amperage control only — electrode always hot		
Extension Cables	#242 208 025 #242 208 050 #242 208 080	25 ft. (7.6 m) 50 ft. (15.2 m) 80 ft. (24.4 m)		
Cable Connectors and Adapters				
Dinse-Style Connector	#042 418	#4 to #1/0 AWG cable size		
Extension Kit for Dinse-Style Connector	#042 419	#4 to #1/0 AWG cable size		
Dinse/Tweco® Adapter	#042 465	One-piece adapter with Dinse-style male plug and Tweco-style female receptacle		
Dinse/Cam-Lok Adapter	#042 466	One-piece adapter with Dinse-style male plug and Cam-Lok receptacle		
Tweco®-Style Connector	#191 981	#1/0 to #2/0 AWG cable size		
Tweco®/Dinse Adapter	#210 061	One-piece adapter with Tweco-style male plug and Dinse-style female receptacle		
Trailers and Hitches				
HWY-224 Trailer	#043 805	Trailer with lights, fenders and 2-in. (50 mm) ball hitch. For highway use		
Cable Tree	#043 826	Trailer-mounted cable holder for HWY-224		
Dual Hitch	#300 831	Combination 2-in. (50 mm) ball hitch and 3-in. (76 mm) lunette eye in one reversible assembly for HWY-224		

Date:

Total Quoted Price:

Distributed by:

