

# Continuum™ Systems

**Advanced MIG  
Welding Systems** 

## Quick Specs

### Heavy Industrial Manufacturing

Construction equipment  
Automotive components  
Recreational vehicles  
Farm machinery  
Office furniture  
Mining machinery  
Industrial fabrication

### Processes

Advanced MIG processes:  
Accu-Pulse® pulsed MIG (GMAW-P)  
Versa-Pulse™  
RMD®  
MIG (GMAW)  
High-deposition MIG (GMAW)  
Flux-cored (FCAW)  
Air carbon arc (CAC-A)  
**350:** Rated for 1/4-inch carbons  
**500:** Rated for 3/8-inch carbons

**Input Power** Auto-Line™ 230–575 V  
3-phase, 50/60 Hz

### Rated Output

**350:** 350 A at 100% duty cycle  
**500:** 500 A at 100% duty cycle

### Output Range

**350:** 20–400 A, 10–44 V  
**500:** 20–600 A, 10–44 V

## Take your welding to the next level

*Advanced industrial welding solution improves productivity through weld quality, ease of use and system flexibility.*

The Continuum system delivers exceptional arc performance with less spatter and higher-quality welds on both thin and thick metals. With user-friendly controls and system modularity, Continuum will make challenging jobs easier, and improve productivity — giving you a competitive advantage.

## Insight

Integrated Welding Intelligence™ solutions deliver information to measure and improve your welding operation. See page 6 for more information.



New standard for productivity and weld quality



Reduce set-up time



Easy to add capabilities

Continuum 500 MIGRunner™ package shown (cable hanger, MIG 4/0 kit and motor cable not pictured). Filler metal sold separately.



Power source is warranted for three years, parts and labor.  
Original main power rectifier parts are warranted for five years.  
Gun warranted for 90 days, parts and labor.



**Miller Electric Mfg. LLC**  
An ITW Welding Company  
1635 West Spencer Street  
P.O. Box 1079  
Appleton, WI 54912-1079 USA

**Equipment Sales US and Canada**  
Phone: 866-931-9730  
FAX: 800-637-2315  
International Phone: 920-735-4554  
International FAX: 920-735-4125

**MillerWelds.com**



# Continuum™ System Features

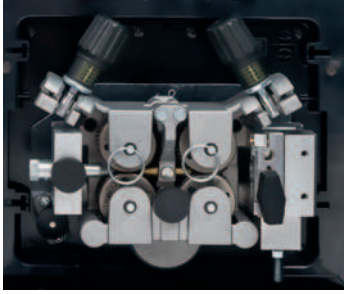

**Tru-Feed™ technology** provides precise feeding operation for stable arc performance.

- **Low-inertia motor** provides faster response for the best arc starts with the least amount of spatter.
- **Balanced-pressure drive-roll design and tensioners** feed wire in its truest and straightest form for consistent feedability, resulting in better welding performance.

**Spring-loaded Accu-Mate™ connection** aligns gun perfectly in the drive-roll carrier — preventing the gun from being pulled loose and providing consistent wire feeding.



**Quick-change dual-bearing drive rolls** give you more consistent wire feeding.

**Drive rolls and guides are common** with other Miller industrial feeders (use existing, not new parts).

**Inlet guide installation is toolless.**

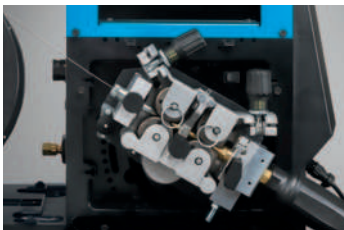

**Toolless positive-locking rotatable drive assembly** allows operator to rotate the drive, eliminating severe bends in the wire feed path. This extends gun-liner life and aids in feeding difficult wires.



**Display and controls** for program select, volts/arc length and wire feed speed

**Memory buttons** for quick program recall

**LCD setup screen**

- For easy selection of welding processes and functions
- Industrial design, full color display

**Arc control** to fine tune the welding arc

**Trigger hold, jog and purge buttons**



**Quality-engineered rear cable management** protects your connections to keep you productive.

**Wind Tunnel Technology™**

Internal air flow that protects electrical components and PC boards from dirt, dust, debris — greatly improving reliability.

**Fan-On-Demand™** operates only

when needed reducing noise, power consumption, and the amount of airborne contaminants pulled through the machine.

**AUTO-LINE™**  
TECHNOLOGY

Allows for any input voltage hookup (230–575 V) with no manual linking. Provides convenience in any job setting and eliminates weld defects caused by dirty or unreliable power.

# Continuum™ System Advantages

## Intuitive user interface makes Continuum easier to use



Reduce set-up time

**Simple to set up** and adjust with minimal training.

**LCD display** shows complete words, graphics and numeric values.

**Memory buttons** allow weld operators to quickly and easily change programs.

**Remote connection** to easily view and adjust machine parameters from virtually anywhere in the world using any Web-enabled device.

**Easily update firmware**, configure machine settings, view diagnostics and more.

**USB functionality** allows custom settings to be saved on a USB flash drive for duplicating settings for a specific operator, job, or to manage fleet configurations. The USB port is also used to update software.

**Ability to set locks and limits** for improved quality control using webpages.



*The Continuum user interface makes machine operation easier than ever.*

## Easy system interface and configuration via the Continuum webpage interface

- To use the webpage interface connect to the Continuum power source one of three ways:



Connect to factory network via Wi-Fi



Connect to factory network via Ethernet cable



Direct connect to PC via Ethernet cable (see page 10 for recommended Ethernet cable)

- Select language preference
- Check system status and vital information
- Configure machine settings
  - Locks and limits
  - Enable programs
  - Enable processes
- Set up programs
- View productivity information and various logs
  - Resettable/lifetime arc hours
  - Error logs
  - Heat input
  - And more
- Great for validating proper system setup as well as troubleshooting issues

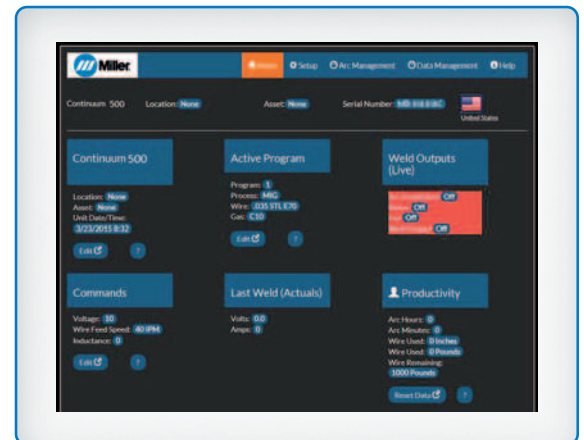

## Continuum grows with your business needs

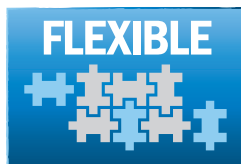

Easy to add capabilities

**Adaptable** to a variety of weld cell configurations and requirements.

**Control interface** can be located on the bench feeder or on the remote operator interface (ROI) (see page 11 for configurations).

**Welding Intelligence™** Improve your welding operations by increasing productivity, improving quality and managing costs.

**Easily add processes and programs** via the USB interface.

**Wire feeder is easily configurable** for standard spool sizes, 60-pound spools or bulk-feeding systems.

**Auxiliary power outlets** (factory option) for convenient operation of 120-volt electrical devices.

# Continuum™ System Processes

## Take the performance of each process to the highest level

### Accu-Pulse®

- The most popular process for majority of industrial welding applications
- Most adaptive arc on 16 gauge (1.6 mm) and thicker
- Designed for all weld positions

### Versa-Pulse™

- Fast, low-heat, low-spatter process — for materials 1/4 inch (6.35 mm) and thinner
- Great for gap filling
- Shortest arc length/lowest pulse voltage for lower heat and lower spatter at higher speeds

### RMD®

- Lowest heat process, best for gap handling
- Limited travel speed

### MIG

- Lower spatter than traditional MIG welders
- Better arc performance with silicon bronze and coated materials

### High-deposition MIG

- Higher deposition rates than standard spray transfer on thicker materials
- Designed for welding applications in which spray transfer is preferred

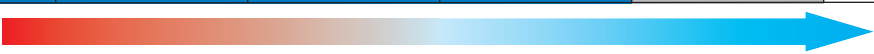

Best For	Standard Spray	High-Deposition MIG	Accu-Pulse	Versa-Pulse	Short Circuit	RMD
Deposition	A	A	A	B	D	D
Gap Filling	D	D	B	B	A	A
Low Heat Input	D	C	B	A	A	A
Out-of-Position Welds			A	B	B	B
Low Spatter	A	A	A	B	C	B
Thick Metals	A	A	A	C	D	D
Thin Metals			B	A	A	A
Increased Travel Speed	A	A	A	A	B	C

HOT  COLD

Ratings A, B, C, and D are relative values. An "A" rating indicates a best fit between your performance needs and process. A "blank" rating indicates that the process is not recommended for that application.



# Continuum™ Power Source Specifications (Subject to change without notice.)



Model	Amp/Volt Ranges	Rated Output	Amps Input at Rated Output, 50/60 Hz, 3-Phase							Max. Open-Circuit Voltage	Dimensions	Net Weight
			230 V	380 V	400 V	460 V	575 V	KVA	KW			
Continuum 350	20–400 A 10–44 V	350 A at 31.5 VDC, 100% duty cycle	36.7 0–1*	21.8 0–1*	20.8 0–1*	18.8 0–1*	14.6 0–1*	14.4 0.8*	13.8 0.17*	71 VDC	H: 27.19 in. (691 mm) (including lift eye)	127 lb. (57.6 kg)
Continuum 500	20–600 A 10–44 V	500 A at 39 VDC, 100% duty cycle	57.6 0–1*	34.7 0–1*	33.2 0–1*	28.9 0–1*	23.3 0–1*	23.1 0.8*	21.9 0.17*	71 VDC	W: 17.5 in. (444 mm) D: 28.13 in. (714 mm)	148 lb. (67.1 kg)

\*While idling.

Certified by Canadian Standards Association to both the Canadian and U.S. Standards.

# Continuum™ Feeder Specifications (Subject to change without notice.)



Input Power	Welding Power Source	Input Welding Circuit Rating	Wire Feed Speed	Wire Diameter Capacity	Maximum Spool Size Capacity	Dimensions	Net Weight
50 VDC	Continuum 350 or 500	500 A at 100% duty cycle	<b>Standard</b> 50–1,000 ipm (1.27–25.4 m/min.)	.035–5/64 in. (0.9–2.0 mm)	18 in. (457 mm) 60 lb. (27 kg)	H: 13.81 in. (351 mm) Single W: 16.31 in. (414 mm) Dual W: 17 in. (432 mm) D: 29.69 in. (754 mm)	<b>Single</b> 43 lb. (19.5 kg) <b>Dual</b> 61.5 lb. (27.9 kg)

Certified by Canadian Standards Association to both the Canadian and U.S. Standards.

## Performance Data

Duty Cycle Chart

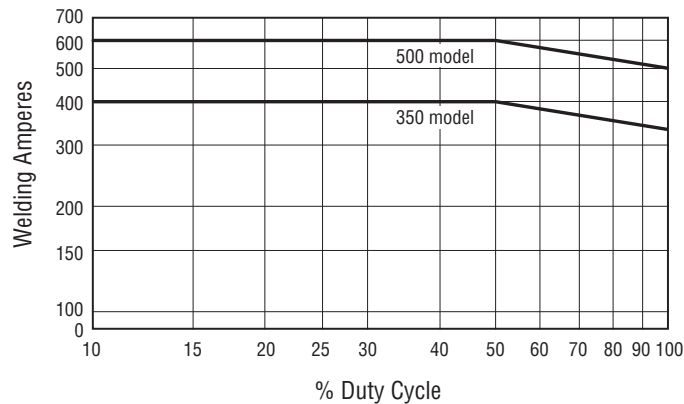

## Mounting Specifications

Bottom View

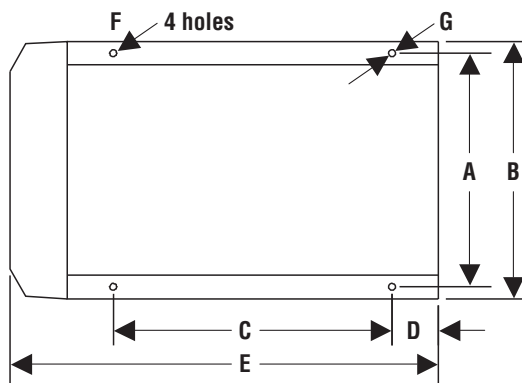

- A. 16.093 in. (409 mm)
- B. 17.5 in. (444 mm)
- C. 17.375 in. (441 mm)
- D. 2.281 in. (58 mm)
- E. 26.172 in. (665 mm)
- F. .468 in. (12 mm) dia.
- G. .468 in. x 1 in. (12 x 25 mm)

**Height:** 27.187 in. (691 mm)  
**Width:** 17.5 in. (444 mm)  
**Depth:** 28.125 in. (714 mm)

Transform data into actionable information that drives continuous improvement.  
Learn more at [MillerWelds.com/insight](http://MillerWelds.com/insight)



## Insight Core™ (Standard)

Simple, cloud-based welding information management solution that reports operator productivity and deposition, as well as weld parameter verification.

- Provides basic production metrics such as amps, volts, wire feed speed, arc on time and arc on time percentage



## Insight Centerpoint™ (Optional)

Advanced, real-time operator feedback solution to prevent missed welds, enforce proper weld sequences and ensure consistent weld quality.

- With built-in features like Part Tracking™ to detect a bad weld and built-in reporting and welding analytics tools, Insight Centerpoint can help reduce rework costs and improve quality

### Cost of a missed weld or defect

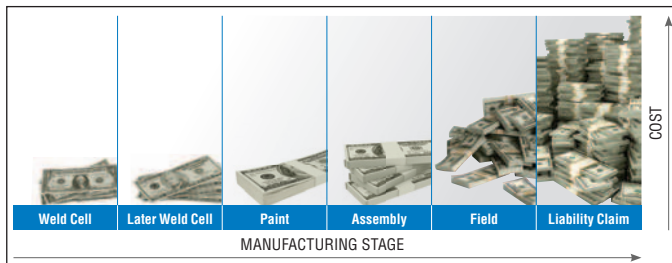

**Part Tracking actively detects a bad weld when it happens to reduce rework and improve quality.**

- Guide new inexperienced welders through the manufacturing process by presenting them with visual work instructions, reducing training time and out-of-date work instructions
- Centerpoint can prevent the next weld from occurring if missing or out-of-spec welds are detected, to alert and direct the operator to which weld(s) are out of parameter, reducing inspection time
- Repair can be done at the weld cell before paint, final assembly, or finished product delivery, which significantly reduces the cost of rework and improves overall parts quality

### Insight Centerpoint Ordering Information

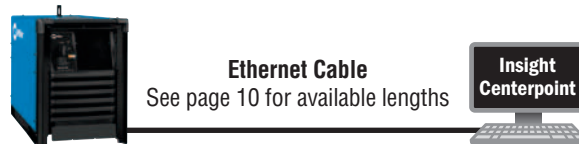

**Ethernet Cable**

See page 10 for available lengths



**Centerpoint 10 License and Activation 951809**

#### Gas Flow Sensors

**301472** Continuum single-wire feeder sensor kit with gas sensor (order two for dual-wire feeders, works with Insight Core and Centerpoint)

**301478** Continuum wire drive sensor kit with gas sensor (works with Insight Core and Centerpoint)



BTB T Series



BTB C Series

#### Insight LTD Guns

**3DM4015-45Q** BTB T Series

**Q4015JS3EML** BTB C Series

Visit [BernardWelds.com](http://BernardWelds.com) to customize your MIG Gun.

**Insight LTD Remote 301383**

Wired remote that can be added to any MIG gun. Provides controls for Insight Centerpoint.

# Continuum™ Swingarc™

## Continuum Swingarc™

### Boom-Mounted Wire Feeders

**951635** 12 ft. (3.7 m) single-wire

**951636** 16 ft. (4.9 m) single-wire

**951725** 12 ft. (3.7 m) dual-wire

Requires pipe post **OR** pipe post and Swingpak for mounting. See below.

### Pipe Post

**149838** 4 ft. (1.2 m) pipe post

**149839** 6 ft. (1.8 m) pipe post

Required for mounting 12- or 16-foot Swingarc booms. Pipe posts have 18-inch base plates which allow the post to be bolted to floor or optional Swingpak base.

### Swingpak™ Base

**183997** Swingpak base

Optional base for Swingarc booms.

Pipe post easily bolts to base.



### Single/Dual Spool Carrier

**300353** For 4 ft. post

**300352** For 6 ft. post

Pipe post not included. Must be ordered separately.

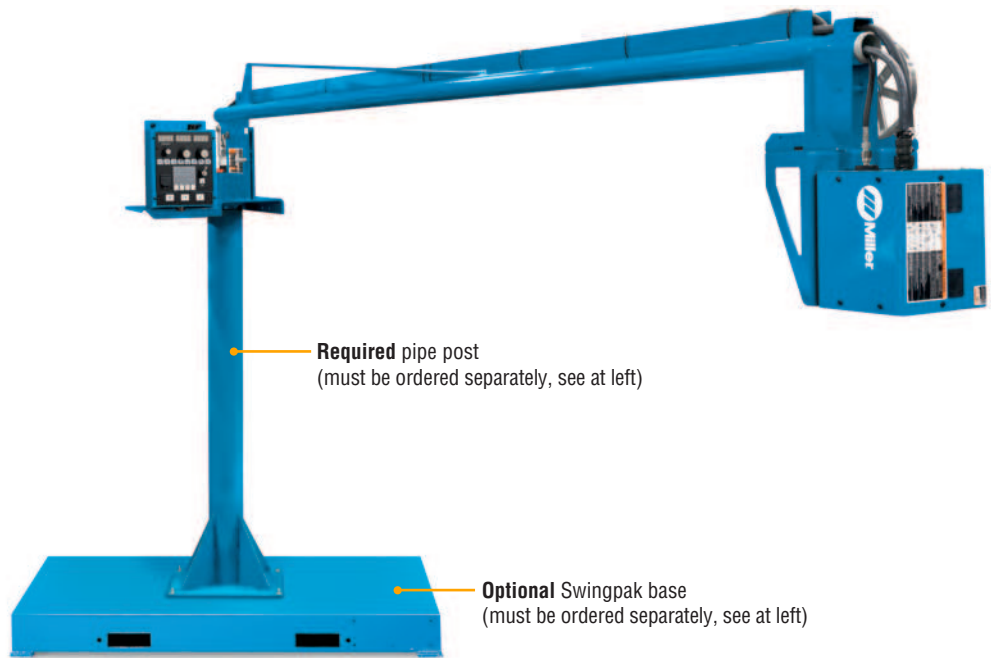

**Required** pipe post  
(must be ordered separately, see at left)

**Optional** Swingpak base  
(must be ordered separately, see at left)

**12- or 16-foot booms** to accommodate a wide variety of semiautomatic applications, including large weldments and hard to reach areas. *Note: Dual-wire model only available with a 12-foot boom.*

**360-degree rotation and 60-degree lift angle** maximizes your work area (24- or 32-foot diameter work area).

**Unique counterbalanced boom** makes it easy to raise and lower boom and automatically holds its position.

**In-boom cable routing** organizes hoses and cables, preventing damage and maintaining an orderly work cell.

## Specifications (Subject to change without notice.)

Component	Dimensions	Net Weight
<b>4 ft. pipe post</b>	H: 4 ft. (1.2 m)	110 lb. (49.9 kg)
<b>6 ft. pipe post</b>	H: 6 ft. (1.8 m)	130 lb. (59 kg)
<b>Swingpak base</b>	L: 65 in. (1.7 m), W: 50.875 in. (1.3 m)	285 lb. (129 kg)

*Note: Swingarc includes 10-foot gas hose and 10-foot weld cable for the operator to hook up.*

## Continuum™ Packages

951853  
package shown



### Steel (push-only) MIGRunner™ Packages

951852 Continuum 350 MIGRunner, air cooled

951853 Continuum 500 MIGRunner, air cooled

#### Packages include:

- Continuum welding power source with running gear/cylinder rack and cable hanger
- Continuum single-wire feeder
- 15 ft. (4.6 m) Bernard® BTB Gun 400 A
- 3 ft. (0.9 m) control/motor cable
- Industrial MIG 4/0 kit for single-wire feeders consisting of flowmeter regulator with 10 ft. (3 m) gas hose, 10 ft. (3 m) 4/0 feeder weld cable with lugs, and 15 ft. (4.6 m) work cable with 600-amp C-clamp
- .035/.045 in. V-groove drive rolls

951855  
package shown



### Multi-material (push-pull) MIGRunner™ Packages

951854 Continuum 350 MIGRunner, air cooled

951855 Continuum 500 MIGRunner, air cooled

#### Packages include:

- Continuum welding power source with running gear/ cylinder rack and cable hanger
- Continuum dual-wire feeder
- 25 ft. (7.6 m) XR-Aluma-Pro™ Plus push-pull gun
- 15 ft. (4.6 m) Bernard® BTB Gun 400 A
- 3 ft. (0.9 m) control/motor cable
- Industrial MIG 4/0 kit for dual-wire feeders consisting of two flowmeter regulators with two 10 ft. (3 m) gas hoses, 10 ft. (3 m) 4/0 feeder weld cable with lugs, and 15 ft. (4.6 m) work cable with 600-amp C-clamp
- .035/.047 in. U-groove and .035/.045 in. V-groove drive rolls



## Bernard® Best of the Best (BTB) MIG Gun



### Bernard BTB Gun 400 A Q4015VS3EML

Straight handle MIG gun ships with Continuum feeders and has the best of all Bernard options. This 400-amp, air-cooled MIG gun is recommended for heavy manufacturing environments and features a fixed 60-degree neck with aluminum armor. It has an ergonomic handle with rubber grip and rear ball and socket swivel to maximize comfort while welding.



### Standard QUICK LOAD™ liner AutoLength™ system.

- **QUICK LOAD liners** require less than half the time and effort to replace (compared to conventional liners)
- **The liner feeds from the front of the MIG gun** — no need to remove the gun from the feeder or to cut and waste wire
- **The AutoLength power pin** contains a spring-loaded module that applies constant pressure on the liner, keeping it seated properly in the retaining head
- **Allows for up to one-inch (2.54 cm) forgiveness** if the liner is too short or moves during welding
- **Reduces burnbacks and improves wire feedability** by aligning wire from liner with contact tip

## XR™ Push-Pull Guns (ONLY for use with left-hand drive of dual-wire bench feeders.)



### XR-Aluma-Pro™ Plus Guns

- 300000001** 15 ft. (4.6 m), air-cooled
- 300001001** 25 ft. (7.6 m), air-cooled
- 300003001** 15 ft. (4.6 m), water-cooled
- 300004001** 25 ft. (7.6 m), water-cooled



### XR™-Pistol Plus Guns

- 300753** 15 ft. (4.6 m), air-cooled
- 300754** 25 ft. (7.6 m), air-cooled
- 300755** 35 ft. (10.6 m), air-cooled
- 300757** 25 ft. (7.6 m), water-cooled
- 300758** 35 ft. (10.6 m), water-cooled

Available in air- or water-cooled versions in multiple lengths for extended reach with trouble-free, reliable feeding.

**Aluminum-series-specific tension setting** ensures smooth wire feeding performance with 4000 or 5000 series aluminum wires.

**Replaceable feed cable liner** is designed to provide consistent arc performance. It also reduces parts cost and service time by allowing a simple means of removing and replacing liner and not the complete feed cable.

**Easy-to-rotate self-seating head tube** allows for better access into tight spots, providing excellent current transfer.

**Isolated common knurled drive roll** helps reduce wear, reducing down time and cost.

**Serviceability.** These guns feature a full-length hook-and-loop seamed leather jacket with integrated strain reliefs for easy cable maintenance and protection. Additionally, the Aluma-Pro Plus guns feature quick connections between the control cable and electrical components (trigger, motor, potentiometer).

### Specifications (Subject to change without notice.)

Model	Welding Current Rating	Wire Feed Speed	Wire Type and Diameter Capacity	Dimensions	Net Weight (Gun only)
XR-Aluma-Pro Plus (Air-cooled)	300 A at 100% duty cycle	70–900 ipm (1.8–23 m/min.) dependent on feeder used	.030–1/16 in. (0.8–1.6 mm) aluminum wire Requires wire kit <b>230708</b> to run 1/16 in. (1.6 mm) wire	H: 5 in. (127 mm) W: 2.5 in. (64 mm) D: 17 in. (432 mm)	2.5 lb. (1.1 kg)
XR-Aluma-Pro Plus (Water-cooled)	400 A at 100% duty cycle	70–900 ipm (1.8–23 m/min.)		H: 5 in. (127 mm) W: 2.5 in. (64 mm) D: 17 in. (432 mm)	2.9 lb. (1.3 kg)
XR-Pistol Plus (Air-cooled)	200 A at 100% duty cycle 250 A at 60% duty cycle	70–900 ipm (1.8–23 m/min.)	.030–1/16 in. (0.8–1.6 mm) aluminum wire Requires wire kit <b>230708</b> to run 1/16 in. (1.6 mm) wire	H: 7.375 in. (187 mm) W: 1.875 in. (48 mm) D: 10.625 in. (270 mm)	2.2 lb. (1 kg)
XR-Pistol Plus (Water-cooled)	400 A at 100% duty cycle				2.4 lb. (1.1 kg)

Certified by Canadian Standards Association to both the Canadian and U.S. Standards. Conforms to European standards.

Note: XR-Aluma-Pro Plus and XR-Pistol Plus guns are only compatible with MPA Plus feeders and the left-hand drive of Continuum dual-wire bench feeders.

# Genuine Miller® Accessories



### Continuum™ Running Gear/Cylinder Rack 301264

Small footprint and easily maneuverable, with cylinder rack low enough that you do not have to lift bottles.



### Industrial MIG 4/0 Kit

**300390** For single-wire feeders

**300957** For dual-wire feeders

Consists of flowmeter regulator with 10-foot (3 m) gas hose, 10-foot (3 m) 4/0 feeder weld cable with lugs, and 15-foot (4.6 m) work cable with 600-amp C-clamp. Dual kit comes with two flowmeter regulators and gas hoses.



### Continuum Handles/Cable Hanger 301585

Used to hang welding cables or MIG guns when not welding.



### Hanging Bail 058435

Used for suspending feeder over work area.

### Spool Covers

**274613** Left cover

**274611** Left case

**276961** Right cover

**276962** Right case

### Continuum Control/Motor Cables

**263368003** 3 ft. (0.9 m)

**263368015** 15 ft. (4.6 m)

**263368025** 25 ft. (7.6 m)

**263368050** 50 ft. (15.2 m)

**263368080** 80 ft. (24.4 m)

**263368100** 100 ft. (30.5 m)

Connects power source to feeder or remote operator interface. Also connects remote operator interface to remote motor drive.

### Volt-Sense Cables

**242212025** 25 ft. (7.6 m)

**242212050** 50 ft. (15.2 m)



### Ethernet Cables

**300734** 9.8 ft. (3 m)

**300736** 32.8 ft. (10 m)

Ethernet cables with M12/RJ45 connectors. Connects power source to Ethernet port of PC or network. For use with webpages and Insight Centerpoint™.

## Coolant Systems



### Continuum Cooler 301214

For use with water-cooled torches rated up to 500 amps. Integrated coolant





flow switch ensures coolant is flowing in the system. The Continuum cooler mounts to the bottom of the Continuum power source. Power is supplied via an internal connection with the power source.

### Low-Conductivity Coolant 043810

Sold in cases of four one-gallon recyclable plastic bottles. Miller coolants contain a base of ethylene glycol and deionized water to protect against freezing to -37 degrees Fahrenheit (-38°C) or boiling to 227 degrees Fahrenheit (108°C). Also contains a compound that resists algae growth.

## Drive Roll Kits and Guides

Select drive roll kits from chart below according to type and wire size being used. Drive roll kits include four drive rolls, necessary guides and feature an anti-wear sleeve for inlet guide.

Wire Size	V-groove for hard wire 	U-groove for soft wire or soft-shelled cored wires 	V-knurled for hard-shelled cored wires 	U-cogged for extremely soft wire or soft-shelled cored wires (i.e., hard facing types) 	U-groove for aluminum wires contains nylon guides 
.035 in. (0.9 mm)	<b>151026</b>	—	<b>151052</b>	—	<b>265255</b>
.040 in. (1.0 mm)	<b>161190</b>	—	—	—	—
.045 in. (1.1/1.2 mm)	<b>151027</b>	<b>151037*</b>	<b>151053</b>	<b>151070</b>	<b>265256*</b>
.052 in. (1.3/1.4 mm)	<b>151028</b>	—	<b>151054</b>	—	—
1/16 in. (1.6 mm)	<b>151029</b>	<b>151039</b>	<b>151055</b>	<b>151072</b>	<b>265257</b>
.068/.072 in. (1.8 mm)	—	—	<b>151056</b>	—	—
5/64 in. (2.0 mm)	—	—	<b>151057</b>	—	—
3/32 in. (2.4 mm)	—	<b>151041</b>	<b>151058</b>	—	—

\*Accommodates .045- and .047-inch (3/64-inch) wire.

### Nylon Wire Guides for Feeding Aluminum Wire

Wire Size	Inlet Guide	Intermediate Guide
.035 in. (0.9 mm)	<b>221912</b>	<b>242417</b>
.047 in. (1.2 mm)	<b>221912</b>	<b>205936</b>
1/16 in. (1.6 mm)	<b>221912</b>	<b>205937</b>

Note: U-groove drive rolls are recommended when feeding aluminum wire.

### Wire Guides

Wire Size	Inlet Guide	Intermediate Guide
.023–.040 in. (0.6–1.0 mm)	<b>221030</b>	<b>149518</b>
.045–.052 in. (1.1–1.4 mm)	<b>221030</b>	<b>149519</b>
1/16–5/64 in. (1.6–2.0 mm)	<b>221030</b>	<b>149520</b>
3/32–7/64 in. (2.4–2.8 mm)	<b>229919</b>	<b>149521</b>

# Typical Continuum™ Installations

## Standard installation

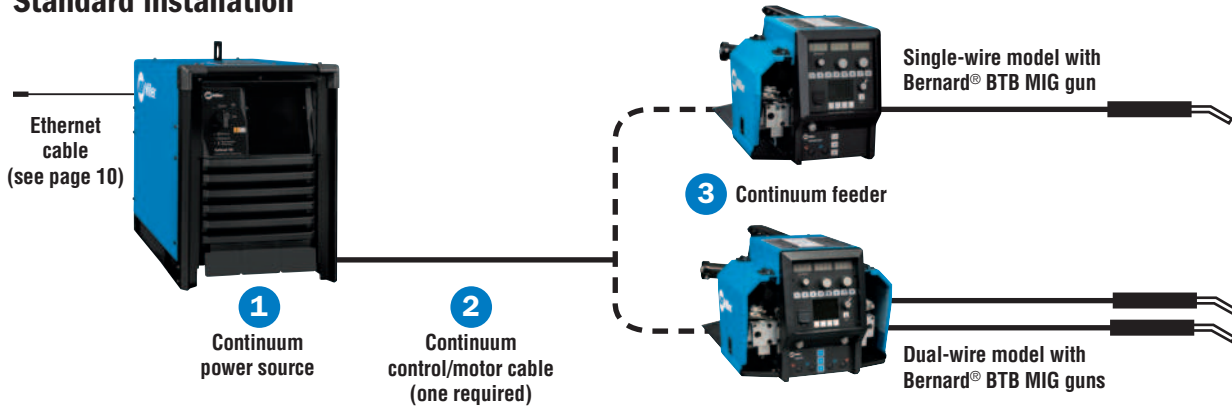

## Swingarc boom-mounted installation

Accommodates a wide variety of semi-automatic applications, including large weldments and hard-to-reach areas.

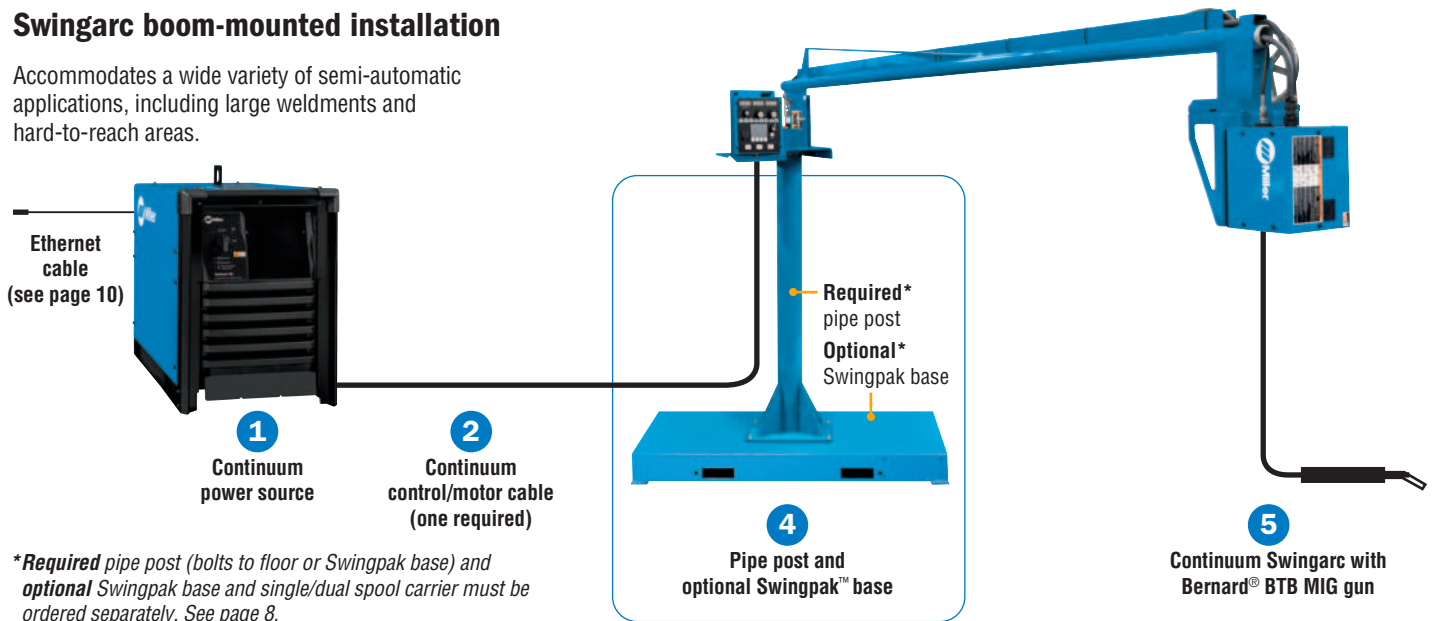

\*Required pipe post (bolts to floor or Swingpak base) and optional Swingpak base and single/dual spool carrier must be ordered separately. See page 8.

## Remote drive motor installation

Ideal for fixed automation and boom applications where the wire drive motor is installed/controlled remotely.

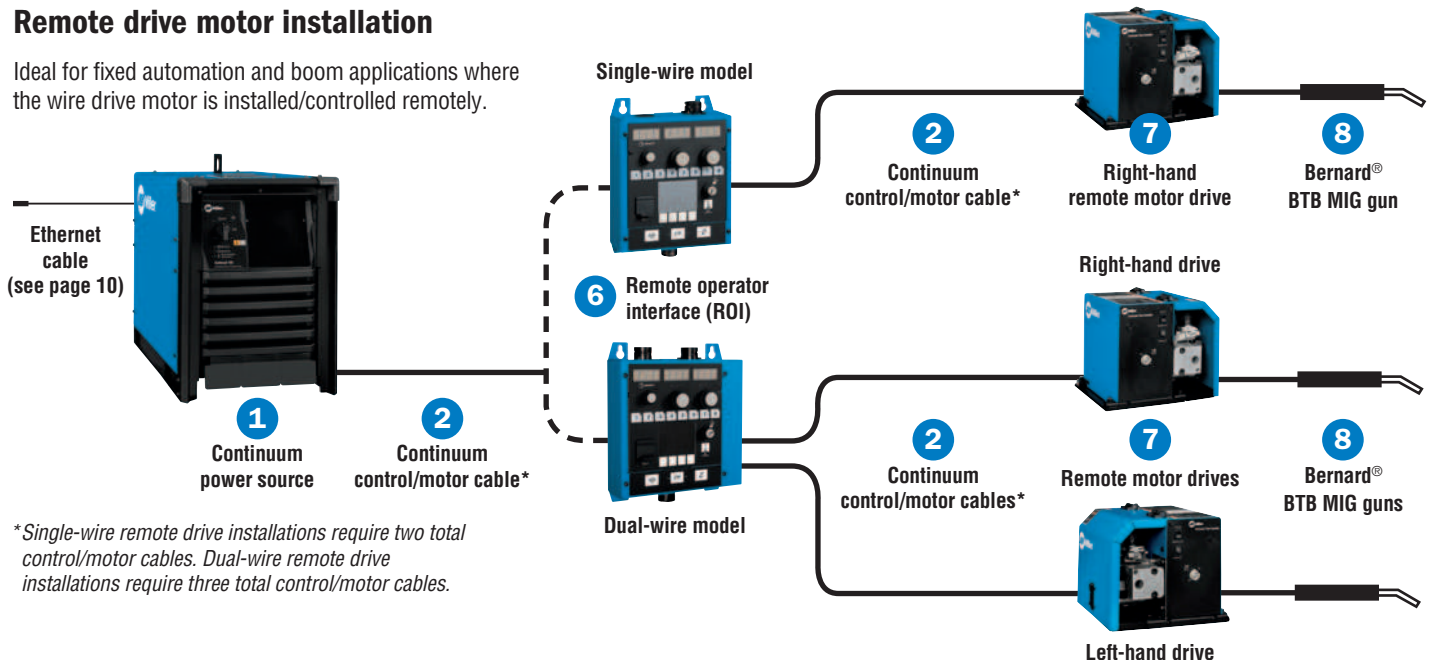

\*Single-wire remote drive installations require two total control/motor cables. Dual-wire remote drive installations require three total control/motor cables.

# Ordering Information

Continuum Packages	Stock No.	Description	Qty.	Price
Continuum™ 350 MIGRunner™	951852	Push-only package. Includes single-wire bench feeder with Bernard BTB gun.		
Continuum™ 500 MIGRunner™	951853	See page 8 for complete package description		
Continuum™ 350 MIGRunner™	951854	Push-pull package, Includes dual-wire bench feeder with XR-Aluma-Pro™ Plus push-pull gun and Bernard® BTB Gun. See page 8 for complete package description		
Continuum™ 500 MIGRunner™	951855			
<b>Configure a Custom Continuum System (See corresponding item numbers in Typical Continuum Installations on page 11.)</b>				
<b>Power Sources</b>				
<b>1</b> Continuum™ 350	907636	Power source only		
	907636001	Power source with running gear/cylinder rack		
	907637	Power source with auxiliary power		
Continuum™ 500	907640	Power source only		
	907640001	Power source with running gear/cylinder rack		
	907641	Power source with auxiliary power		
<b>Wire Feeders and Gun</b>				
<b>3</b> Continuum™ Bench-Style Wire Feeders	951631	Single-wire model with Bernard BTB Gun 400 A and .035/.045 in. V-groove drive rolls		
	951673	Dual-wire model with two Bernard BTB Guns 400 A and .035/.045 in. V-groove drive rolls		
<b>5</b> Continuum™ Swingarc™ Boom-Mounted Wire Feeders	951635	12 ft. single-wire model with Bernard BTB Gun 400 A and .035/.045 in. V-groove drive rolls		
	951636	16 ft. single-wire model with Bernard BTB Gun 400 A and .035/.045 in. V-groove drive rolls		
	951725	12 ft. dual-wire model with two Bernard BTB Guns 400 A and .035/.045 in. V-groove drive rolls		
<b>6</b> Remote Operator Interface	301227	Control box for single-wire drive assembly		
	301434	Control box for dual-wire drive assembly		
<b>7</b> Remote Motor Drive	301216	Left-hand single-wire drive assembly		
	301215	Right-hand single-wire drive assembly		
<b>8</b> Bernard® BTB Gun	Q4015VS3EML	Push-only MIG gun		
XR™ Push-Pull Guns		ONLY for left-hand drive of dual-wire bench feeder. See page 9		
<b>Cables</b>				
<b>2</b> Continuum Control/Motor Cables		See page 10 for available lengths		
Volt-Sense Cables		See page 10 for available lengths		
Ethernet Cables		See page 10 for available lengths		
<b>Swingarc Mounting Equipment</b>				
<b>4</b> Pipe Post		Required for mounting Swingarc booms. See page 7 for available heights		
Swingpak™ Base	183997	Optional mounting platform for pipe post		
<b>Welding Intelligence™ Software</b>				
Insight Centerpoint™	951809	Centerpoint 10 license and activation for Continuum		
Gas Flow Sensors		See page 6 ( <i>contact customer service at 920-954-3809 for retrofit options</i> )		
Insight LTD Guns		Guns provide built-in controls for Insight Centerpoint. See page 6		
Insight LTD Remote	301383	Wired remote that can be added to any MIG gun. Provides controls for Insight Centerpoint		
<b>Accessories</b>				
Running Gear/Cylinder Rack	301264	For Continuum power source		
Industrial MIG 4/0 Kit		Available for single- and dual-wire bench feeders. See page 10		
Continuum Cable Hanger	301585	Used to hang welding cables or MIG guns when not welding		
Hanging Bail	058435	Used for suspending feeder over work area		
Spool Covers		See page 10		
Continuum Cooler	301214	Integrated 2-gallon capacity cooler for water-cooled MIG guns		
Low-Conductivity Coolant	043810	1-gallon plastic bottle ( <i>must be ordered in quantities of 4</i> )		
Boom Retrofit Kits	301470	Single boom. Retrofits Continuum onto 70 Series Swingarc™		
	301471	Dual boom. Retrofits Continuum onto 70 Series Swingarc™		

Date:

Total Quoted Price:

Distributed by:

